

# **GFLUGO**

FZS Coaxial pump



### ◎ FSZ Coaxial Pump



### Application

- Air-condition cold or hot water circulation
- Can be used together with equipment
- Water-supplying system of apartment building
- Industrial water supply
- Fire-fighting water system
- Construction engineering water supply
- Waste water treatment
- Farm water irrigation
- Boiler water supply



# FZS Series - Coaxial Pump

## Features

- The optimal hydraulic model is used for impeller, the pump is of an utmost dynamic-static balance and reliable performance.
- The pump shaft is an extended one from the motor, so the concentricity is absolutely reliable.
- The pump which is supported by imported bearing, runs at little vibration and low noise.
- Single-stage single-suction horizontal centrifugal pump, closed impeller .
- Coaxial volute structure, high efficiency, small volume, light weight, easy installation and maintenance.
- Mechanical seal, no damage to shaft, no leakage, long duration.
- Materials can be selected according to the requirement of the customer. (Material of the pump model in the catalog is cast iron. The size and weight of the pump made of stainless steel can be provided separately.)

## Construction

NO.	Name	Standard Material		Optional Material	
		GB	JIS	GB	JIS
1	Shaft	1Cr13	SUS410	SUS 304	SS 316
2	Bracket	HT200	FC200	SUS 304	SS 316
3	Pump casing	HT200	FC200	SUS 304	SS 316
4	Plug	Q215A	SS34(SS330)	SUS 304	SS 316
5	O-ring	NBR	NBR	NBR	NBR
6	Mechanical seal	C/AL <sub>2</sub> O <sub>3</sub>	C/AL <sub>2</sub> O <sub>3</sub>	C/AL <sub>2</sub> O <sub>3</sub>	C/AL <sub>2</sub> O <sub>3</sub>
7	Impeller	HT200	SS 304	SS 304	SS 304
8	Key	45	S45C	SS 304	SS 316
9	Feet	HT200/Q215A	FC200/SS34(SS330)	HT200/Q215A	FC200/SS34(SS330)
10	Motor				

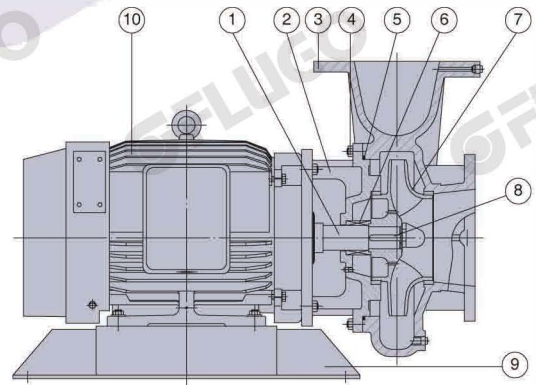

## Type description

